

**OPERATION**

The ATC Diversified **SPM Series** Single Channel Seal Failure module is a specialized control for monitoring the **shaft seal** of a **submersible pump motor**. A leak is detected by sensing the position of a resistive float switch installed in the seal cavity. When the resistance drops below the sensitivity rating, the output relay energizes and the LED illuminates.



*Single Channel Seal Failure Alarm*

**DIMENSIONS (INCHES)**

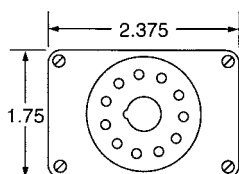
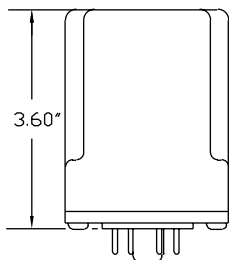

**SPECIFICATIONS**

<b>CONTROL VOLTAGE</b>	120 VAC, 50/60 Hz
<b>SWITCH VOLTAGE</b>	9 VDC
<b>ISOLATION</b>	2500 Volts
<b>POWER REQUIRED</b>	2 VA
<b>DUTY CYCLE</b>	Continuous
<b>SENSITIVITY</b>	470 Ω ±10% Fixed 300 Ω to 10K Ω ±10% Adjustable 4.7K Ω to 100K Ω ±10% Adjustable
<b>CONTACT RATING</b>	DPDT, 10 A @ 250 VAC Resistive, 360 VA Inductive
<b>RESPONSE TIMES</b>	Operate 15 ms (approximately) Release 8 ms (approximately)
<b>LIFE EXPECTANCY</b>	Mechanical 10,000,000 Operations (Minimum) Electrical 50,000 Operations @ Rated Load
<b>INDICATORS</b>	Red LED illuminates when leak is detected
<b>TEMPERATURE RATING</b>	Operate -4° to 131°F (-20° to +55°C) Storage -40° to 185°F (-40° to +85°C)
<b>ENCLOSURE</b>	11-Pin plug-in "A" style enclosure
<b>WEIGHT</b>	8 oz.

**WIRING**

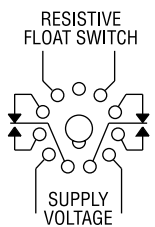

RB-11/PF013A

**MODEL NUMBER**

<b>MODEL NUMBER</b>	SPM	120	AAA	
<b>SENSITIVITY</b>				
470 Ω ±10% Fixed				470
300 Ω to 10K Ω ±10% Adjustable				10K
4.7K Ω to 100K Ω ±10% Adjustable				100K



**CE** **UL** **US**  
E55826

## Dual Channel Seal Failure Alarm

### SPECIFICATIONS

<b>CONTROL VOLTAGE</b>	120 VAC, 50/60 Hz
<b>SWITCH VOLTAGE</b>	9 VDC
<b>ISOLATION</b>	2500 Volts
<b>POWER REQUIRED</b>	2 VA
<b>DUTY CYCLE</b>	Continuous
<b>SENSITIVITY</b>	10K $\Omega$ to 25K $\Omega$ $\pm$ 10% Adjustable 4.7K $\Omega$ to 100K $\Omega$ $\pm$ 10% Adjustable
<b>CONTACT RATING</b>	(2) SPST-N.O., 5 A @ 120 VAC Resistive, 345 VA Inductive
<b>LIFE EXPECTANCY</b>	Mechanical 20 Million Operations Electrical 50,000 Operations @ Rated Load
<b>INDICATORS</b>	Red LED illuminates when leak is detected
<b>TEMPERATURE RATING</b>	Operate -4° to 131°F (-20° to +55°C) Storage -40° to 185°F (-40° to +85°C)
<b>ENCLOSURE</b>	8-Pin plug-in "A" style enclosure
<b>WEIGHT</b>	8 oz.

### MODEL NUMBER

<b>MODEL NUMBER</b>	SPM	120	ABA	
<b>SENSITIVITY</b>	10K $\Omega$ to 25K $\Omega$ $\pm$ 10% Adjustable			25K
	4.7K $\Omega$ to 100K $\Omega$ $\pm$ 10% Adjustable			100K

### OPERATION

The ATC Diversified Electronics **SPM Series dual Seal Failure** module is a specialized control for monitoring the shaft seals of *two submersible pump motors*. Leaks are detected by sensing the conductivity of the contaminating fluid through probes installed in the seal cavity. When a seal begins to leak, the seal failure module energizes one of its SPST output relays indicating that the seal needs to be replaced before the motor is damaged. The sensitivity of the probe inputs is field adjustable. When the resistance between one of the probe inputs and the common connection drops below the sensitivity setting, the corresponding output relay and LED are activated.

### DIMENSIONS (INCHES)

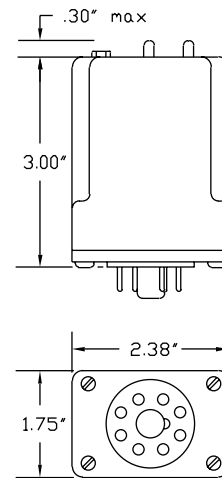

### WIRING

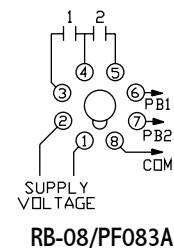

## OPERATION

The non-volatile **Latching Temperature Switch** relay monitors a normally-closed-low temperature switch. It incorporates a bistable relay that retains its state during power failures. LEDs indicate the status of the relay, and connections for an external reset button are provided for manual control. The reset inputs of multiple units may be connected to a single push button as long as proper polarity is observed when making the connections. Under normal conditions the temperature switch is closed and the relay is de-energized. When the temperature switch opens, the relay energizes and latches on until the temperature switch re-closes and the reset button is pressed. The unit will function properly with zero to 2k  $\Omega$  of resistance in series with the temperature switch.



Temperature Switch Relay

## DIMENSIONS (INCHES)

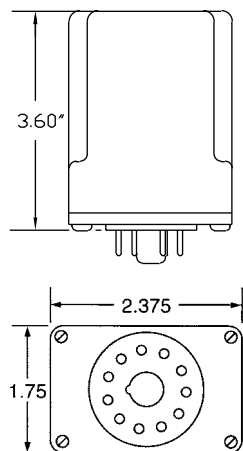

## WIRING

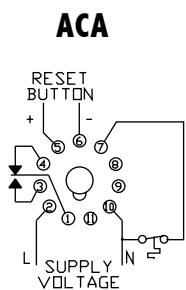

RB-11/PF113A

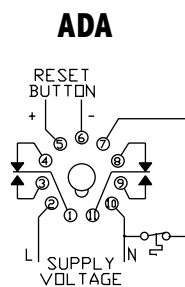

RB-11/PF113A

## SPECIFICATIONS

<b>CONTROL VOLTAGE</b>	120 VAC, 50/60 Hz	
<b>POWER REQUIRED</b>	2 VA	
<b>DUTY CYCLE</b>	Continuous	
<b>CONTACT RATING</b>	SPM-120-ACA	SPDT, 10 A @ 250 VAC, Resistive, 360 VA Ind.
	SPM-120-ADA	DPDT, 10 A @ 250 VAC, Resistive, 360 VA Ind.
<b>RESPONSE TIMES</b>	Operate	10 ms (approximately)
	Release	1 SEC (approximately)
<b>LIFE EXPECTANCY</b>	Mechanical	30 Million Operations
	Electrical	50,000 Operations @ Rated Load
<b>INDICATORS</b>	SPM-120-ACA	Green LED illuminates under normal conditions Red LED illuminates under fault conditions
	SPM-120-ADA	None
<b>TEMPERATURE SWITCH</b>	Voltage	12 VDC
	Current	2 mA max.
<b>TEMPERATURE RATING</b>	Operate	-4° to 131°F (-20° to +55°C)
	Storage	-40° to 185°F (-40° to +85°C)
<b>ENCLOSURE</b>	11-Pin plug-in "A" style enclosure	
<b>WEIGHT</b>	8 oz.	

## ORDERING INFORMATION

MODEL NUMBER	DESCRIPTION
SPM-120-ACA	SPDT, 10A @ 250V AC Latching Temp Switch
SPM-120-ADA	DPDT, 10A @ 250V AC Latching Temp Switch



  
 LISTED  
 IND. CONT. EQ.  
 496Y  
 (Model AEE)

## Submersible Pump Monitor Dual Function Alarm Relay

### SPECIFICATIONS

**CONTROL VOLTAGE** 120 VAC, 50/60 Hz (Model AEE)  
 120-240V AC 50/60 Hz (Model AEA)  
 24V AC/DC (Model AEA)

**SENSOR VOLTAGE** 12 VDC (Model AEE)  
 9V DC (Model AEA)

**POWER REQUIRED** 4 VA

**DUTY CYCLE** Continuous

**SENSITIVITY** Leakage 1K  $\Omega$  to 35K  $\Omega$  adjustable (Model AEE)  
 1K  $\Omega$  to 25K  $\Omega$  adjustable (Model AEA)  
 4.7K  $\Omega$  to 100K  $\Omega$  adjustable (Model AEA)  
 Over Temperature Open Circuit

**CONTACT RATING** (2) SPDT, 10 A @ 120 VAC Resistive

**LIFE EXPECTANCY** Mechanical 10 Million Operations  
 Electrical 100,000 Operations @ Rated Load

**INDICATORS** Green LED illuminates under normal conditions  
 Red LED illuminates when leak is detected  
 Red LED illuminates on over-temperature

**TEMPERATURE RATING** Operate -4° to 131°F (-20° to +55°C)  
 Storage -40° to 185°F (-40° to +85°C)

**RESPONSE TIMES** Leakage Trip 1 SEC  
 Leakage Reset 1 SEC  
 Temperature Trip 0.1 SEC

**TERMINATIONS** (12) #8-32 Screw Terminals (Model AEE)

**ENCLOSURE** Style "E" Lexan® Surface Mounted (Model AEE)  
 Style "A" 11 Pin Plug-In (Model AEA)

**WEIGHT** 17 oz. (Model AEE)

**RESET** Seal Leakage: When the leakage condition clears the relay resets automatically  
 Over Temperature:  
 1. Remote Manual Reset  
 2. For "S" type models when reset switch is set in auto position the unit will be reset by interrupting supply voltage for 1.5 sec.

The ATC Diversified **Submersible Pump Monitor** is a specialized control for monitoring the **shaft seal** and stator **temperature** of a **submersible pump motor**. Seal leakage is detected by either a resistive float switch or a pair of conductive probes installed in the seal cavity. Over-temperature is detected by a normally-closed-low temperature switch mounted on the stator. The over-temperature function incorporates a bistable relay that retains its position during power failures. For (S) models over-temperature reset can be configured by changing the reset switch.

### ORDERING INFORMATION

MODEL NUMBER	DESCRIPTION
<b>SPM120AEE</b>	Dual Function Alarm Relay 120 vac Base Mount.
<b>SPM120AEA25K</b>	Dual Function Alarm Relay 120 vac, 1k to 25 k sensitivity, Plug-in.
<b>SPM24AEA25K</b>	Dual Function Alarm Relay 24v ac/dc, 1k to 25 k sensitivity, Plug-in.
<b>SPM120AEA100K</b>	Dual Function Alarm Relay 120 vac, 4.7k to 100 k sensitivity, Plug-in.
<b>SPM24AEA100K</b>	Dual Function Alarm Relay 24v ac/dc 4.7k to 100 k sensitivity, Plug-in.
<b>SPM120AEA(S)25K</b>	Dual Function Alarm Relay 120 vac, 1k to 25 k sensitivity, Plug-in, reset mode selector switch.
<b>SPM24AEA(S)25K</b>	Dual Function Alarm Relay 24v ac/dc, 1k to 25 k sensitivity, Plug-in, reset mode selector switch.
<b>SPM120AEA(S)100K</b>	Dual Function Alarm Relay 120 vac, 4.7k to 100k sensitivity, Plug-in, reset mode selector switch.
<b>SPM24AEA(S)100K</b>	Dual Function Alarm Relay 24v ac/dc, 4.7k to 100k sensitivity, Plug-in, reset mode selector switch.

### DIMENSIONS (INCHES) MODEL (AEE) BASE MOUNT

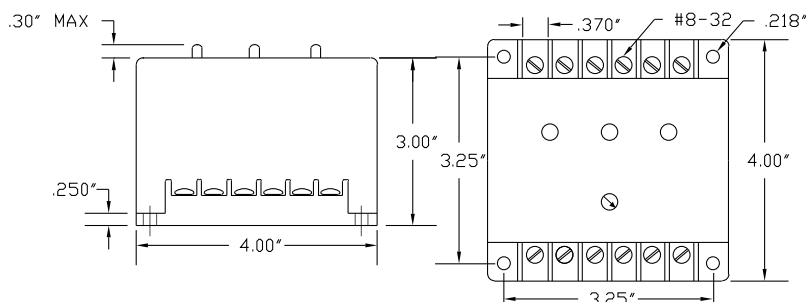

### DIMENSIONS (INCHES) MODEL (AEA) 11 PIN PLUG-IN

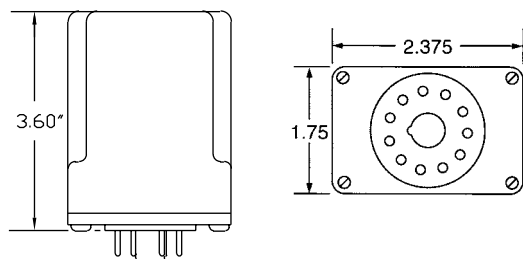

**OPERATION**

Figure 1 shows the connections for use with a Flygt model FLS float switch. The leakage sensitivity must be adjusted to 1 k for float switch applications. If a pair of conductive probes is used to sense seal leakage, a 100 k resistor is required as shown in Figure 2, and the sensitivity should be set to the desired value.

The states of the unit's relay outputs are determined by the series combination resistance of the leakage and temperature sensors. Under normal conditions the resistance remains between the leakage and over-temperature sensitivities, and both output relays are de-energized. If the temperature switch opens, the over-temperature relay latches on until the remote reset button is pressed. Two conditions must be met for reset to occur: power must be applied and the temperature switch must be closed. If the leakage sensor resistance drops below the leakage sensitivity setting, the leakage relay energizes. When the leakage condition clears, the relay resets automatically.

**CAUS**  
E55826  
(Model AEA)



**WIRING MODEL (AEE) (BASE MOUNT)**

Figure 1

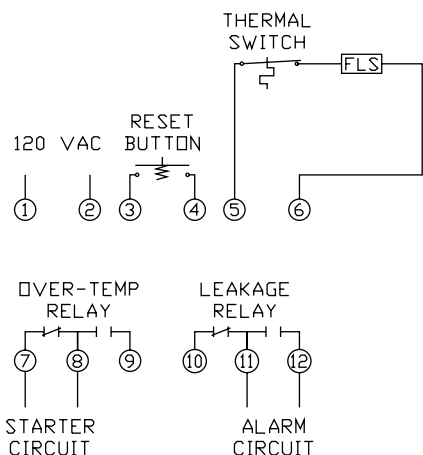
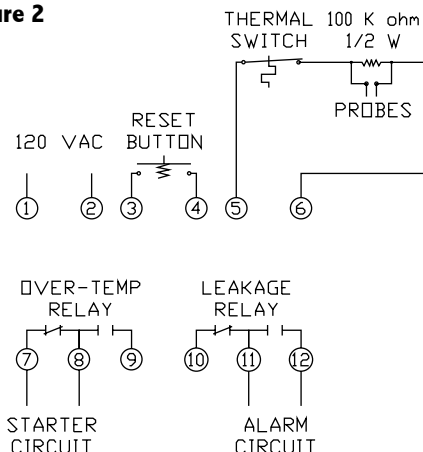

Figure 2



**WIRING MODEL (AEA) (PLUG-IN)**

Figure 1

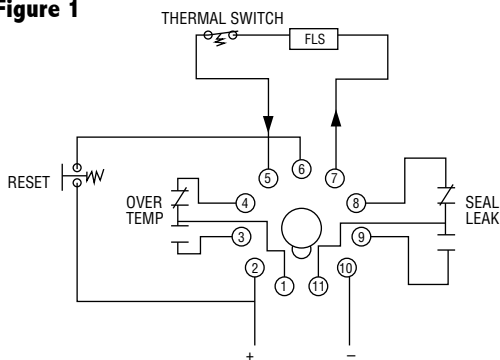
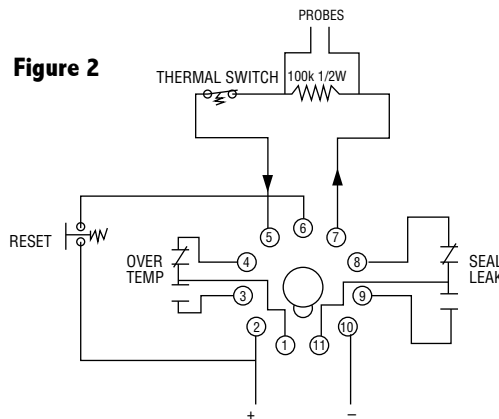

Figure 2



**ACCESSORIES: SOCKETS**

- OT11-PC 11 pin din-rail mount socket.
- RB-11 11 pin surface mount socket.